



FICHA TÉCNICA | ELEVADORES

- ✓ Elevadores a cangilones
- ✓ Capacidades de 10 a 250 tn/hr
- ✓ Gran diversidad de aplicaciones (cereales, harinas, premezclas, sales, etc.)
- ✓ Diseños específicos según aplicación
- ✓ Construcción en acero SAE 1010 o acero inoxidable AISI 304

Modelos de cabezales de Elevadores	Dimensiones en mm			Motor principal [HP]
	A	B	C	
DAB 10	1070	1040	(*)	1.5 - 10
DAB 40	1300	1550	(*)	2 - 12.5
DAB 80	1535	2000	(*)	3 - 20
DAB 150	1810	1760	(*)	15 - 50
DAB 250	1590	1925	(*)	20 - 75

(*) Ajustable según potencia

Modelos de pies de Elevadores	Dimensiones en mm		
	A	B	C
DAB 10	1000	860	255
DAB 40	1400	950	275
DAB 80	1512	1156	390
DAB 150	1520	1030	517
DAB 250	1540	1170	600

Modelos de pantalón de Elevadores	Dimensiones en mm		
	A	B	C
DAB 10	(*)	860	255
DAB 40	(*)	950	275
DAB 80	(*)	1156	375
DAB 150	(*)	1030	517
DAB 250	(*)	1170	590

(*) Medidas variables según proyectos



BERANDEBI

CABEZALES DE ELEVADORES

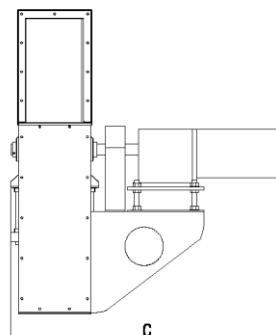
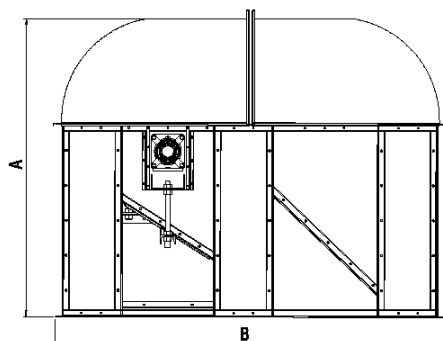

PIES DE ELEVADORES

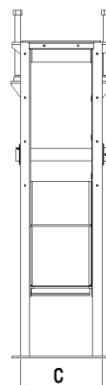
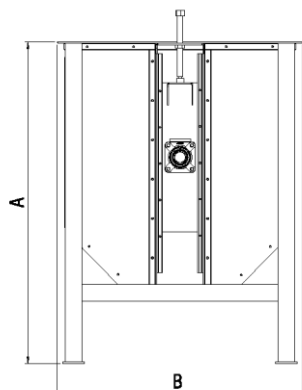

PANTALONES DE ELEVADORES

